

**CASCAD E**

HEALTH & FITNESS®

**CASCADE ROWER PLUS  
OWNER'S MANUAL**

# CASCADE ROWER PLUS™

CASCADE HEALTH AND FITNESS LLC

PO BOX 1318

WOODINVILLE WA 98072

PHONE: (425) 402-4062

FAX: (425) 402-4063

EMAIL: [info@cascadehealthandfitness.com](mailto:info@cascadehealthandfitness.com)

[www.cascadehealthandfitness.com](http://www.cascadehealthandfitness.com)

PLEASE KEEP THIS BOOKLET FOR IMPORTANT WARRANTY INFORMATION & FUTURE REFERENCE. PLEASE FILL IN BELOW CHART WITH REQUESTED INFORMATION FOR FUTURE USE.

MODEL NUMBER	39700-00
DATE OF PURCHASE	
SERIAL NUMBER	
DEALER NAME	
DEALER PHONE NUMBER	

## CONGRATULATIONS

You have just become a valued Cascade customer. Our team is committed to making your rowing experience fun and rewarding — offering you detailed product information, expert fitness advice, and direct customer support you can depend on. Thank you for purchasing the Cascade Rower.

This **Cascade Rower Plus** Owner's Manual will help you get the most enjoyment from your new rower. It not only explains all the important features and safety considerations of the **Cascade Rower Plus**, it also includes great workout tips and exercise principles. If at any time you have questions about this information, please call us at (425) 402-4062 and we will be happy to help you. To help us answer your questions quickly, we recommend that you have the serial number of your Rower ready when you call us. The serial number of your Rower is located on Rower frame.

The **Cascade Rower Plus** has been built to deliver an incredible workout, every component of the **Cascade Rower Plus** has been designed to be more durable, more user friendly and more comfortable than any other rower you have ridden. Whether you are a beginning fitness enthusiast or a highly conditioned athlete, you will immediately feel the difference.

### **Greater Comfort and Essential Feedback**

- Console lets you train for top rowing performance – measuring your resistance level, watts, heart rate, 500 meter time, overall time, strokes, strokes per minute, calories and distance – to meet and improve your personal rowing goals.

Finally, its attractiveness and small footprint allows you to position the **Cascade Rower Plus** anywhere in your home/facility for maximum enjoyment; and you'll also enjoy how quiet a **Cascade Rower Plus** workout is. You will quickly discover that the **Cascade Rower Plus** gives you a better rowing experience than any other rower.

## FEATURES

- ✓ **Smooth, quiet magnetic resistance** reduces maintenance and service
- ✓ **Console** – Essential feedback provided to meet your rowing goals – watts, heart rate, strokes, 500 meter time, rpm, calories, time, distance and level.
- ✓ **Durable frame design** — Excellent stability, and 350 lbs. user load
- ✓ **Comfortable Seat** — Ergonomic design that glides smoothly on a durable stainless steel track
- ✓ **Premium nylon belt** – durable, smooth and quiet
- ✓ **8 programs** – quick start, time, meters, calories, strokes, interval 20/10, interval 10/20 and custom interval
- ✓ **Stores in small space** — Rower can stand on end for storage
- ✓ Complete Rower designed for maximum **corrosion resistance**
- ✓ **Wide cross legs** – for maximum stability
- ✓ **Built-in wheels**– easy and quick to move Rower
- ✓ **Large diameter leveler feet** – allows you to make the Rower stable on uneven surfaces
- ✓ The **Cascade Rower Plus** is so smooth and comfortable you can work out much longer than you ever imagined

## OVERVIEW

Please review the rest of this Owner's Manual carefully before you start using your new **Cascade Rower Plus**. The information enclosed here will help you get the most enjoyment out of your workout and includes valuable operating, service, safety, and trouble-shooting information, as well as guidelines for an effective exercise program.

We are confident that you will love your new **Cascade Rower Plus**.

Congratulations on your new rower.

## INDEX

WARRANTY	PAGE 7
SAFETY INSTRUCTIONS/INFORMATION	PAGE 8
DELIVERY/BOX CONTENTS DIAGRAM	PAGE 10
UNPACKING INSTRUCTIONS	PAGE 12
ASSEMBLY INSTRUCTIONS	PAGE 13
GUIDELINES FOR SAFE OPERATION	PAGE 15
BASIC OPERATION	PAGE 17
CONSOLE	PAGE 18
GENERAL EXERCISE GUIDELINES	PAGE 19
MAINTENANCE INSTRUCTIONS	PAGE 21
SPECIFICATIONS	PAGE 22
EXERCISE LOG	PAGE 23

## WARRANTY

PARTS		LABOR
FRAME	LIFETIME	1 YEAR FOLLOWING CUSTOMER INSTALLATION
NON WEARABLE PARTS	5 YEARS	
ELECTRONICS	2 YEAR	
WEARABLES	2 YEAR	

**NEED ASSISTANCE? Customer Service: (425) 402-4062**

**Prior to contacting our Customer Service Department, please have the following information:**

- Your name, Customer Number, Shipping Address & Telephone Number
- Serial Number(s) of the inoperable Rower(s)
- Date(s) of Purchase for the inoperable Rower(s)
- Your Billing Address

The above information will ensure that you are the only one ordering parts under your warranty protection. If warranty replacement parts are shipped to you, you may be required to return the inoperable part(s). To facilitate this process, the following policy has been established:

- Contact our **Customer Service Department** to receive a **Return Authorization #** prior to shipment
- Cascade will incur all UPS Ground freight charges for Warranty Parts ordered for a machine that is less than 90 days old. You are responsible for freight charges on warranty parts for machines that are more than 90 days old. You will not be responsible for freight charges for any returned inoperable parts.
- If an inoperable warranty part(s) must be returned to our Customer Service Department, we will pay the shipping cost and provide detailed return shipping instructions. These instructions will be sent along with your warranty replacement part(s)



# WARNING

When present, this symbol is an indicator that you should proceed cautiously and be alert as your safety is dependent on your attention to the instructions.

When present, this statement is an indication that there are potential hazards that could result in injury or death.

### **PRIOR TO BEGINNING AN EXERCISE PROGRAM, READ ALL INSTRUCTIONS CONTAINED WITHIN THIS DOCUMENT**

1. The Cascade Rower Plus is intended for cardiovascular fitness training and may be used in group or individual settings.
  - a. Use this equipment only for its intended use as described in this manual
  - b. Do not attempt to exercise on the Rower at high speed/higher stroke rate until you have practiced and are comfortable at slower speeds/lower stroke rate.
2. Injury or death may occur from improper use or over-training. Consult a medical doctor or qualified fitness instructor to determine an exercise program appropriate to your level of fitness.
3. Do not expose ANY part of your body or clothing to the drive mechanism as possible injury could occur.
4. In commercial settings, the Cascade Rower Plus should always be used in a supervised environment with qualified instructors.
5. In a home setting, keep unsupervised children away from the unit when not in use.
  - a. Keep children and pets away from the unit while in use.
6. Only use the unit on a stable, level floor.
7. Follow the instructions for safe use of the equipment
8. For safe operation, allow for at least 1 foot (30cm) of free space to either side of the unit and 2 feet (60cm) of free space to the rear and front of the unit.
9. Users, agents, and anyone directing the use of this equipment shall be responsible for determining the



suitability of the product for its intended use as outlined in this manual, including regular maintenance tasks.

Said parties are put on notice that they assume all risk and liability in connection herewithin.

10. Rider capacity of the Cascade Rower Plus is 350 lbs. (159 kg).

The safety level of this equipment can only be maintained by following the guidelines in this manual and examining the equipment regularly for damage and wear.

Damaged or inoperable components should be replaced immediately and the equipment should not be used until it is repaired.

Failure to follow all guidelines above may compromise your exercise experience, expose you and others to injury, and reduce the longevity of the equipment.

## DELIVERY/DIAGRAMS

Upon delivery of your Cascade Rower, take a moment to check the box exterior for any damage and make a note of it on the delivery receipt before signing. Make your delivery agent aware of any concerns you have and that they have been denoted on the delivery receipt. Please contact our Customer Service department (425)402-4062 if there are issues.



Your Cascade Rower Plus will arrive in (2) cartons and will require some assembly. If any of the items are missing, please contact our Customer Service department at (425) 402-4062 or [info@cascadehealthandfitness.com](mailto:info@cascadehealthandfitness.com).

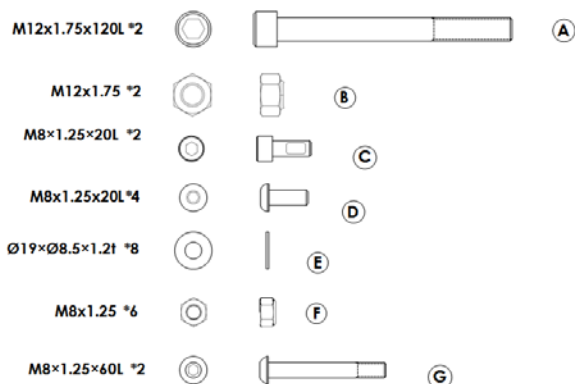
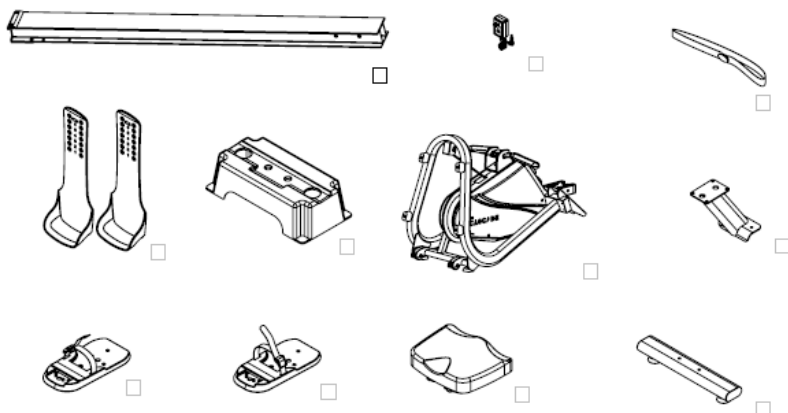

Below is a diagram of the items that you should receive:

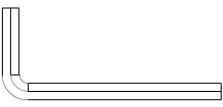

**5mm Allen key**  

**6mm Allen key**  

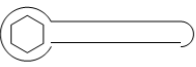
**10mm Allen key**  

**19mm Wrench**  

**13mm Wrench**  

## UNPACKING INSTRUCTIONS

Before leaving the manufacturing facility, your Cascade Rower Plus was thoroughly inspected and tested for proper operation. To minimize shipping damage, careful attention was given to making your Rower ready for shipment.

Prior to opening the box, place it in the room of use where there is a large, clear area in order to facilitate an easy assembly.

Remove straps and lift top to expose contents:

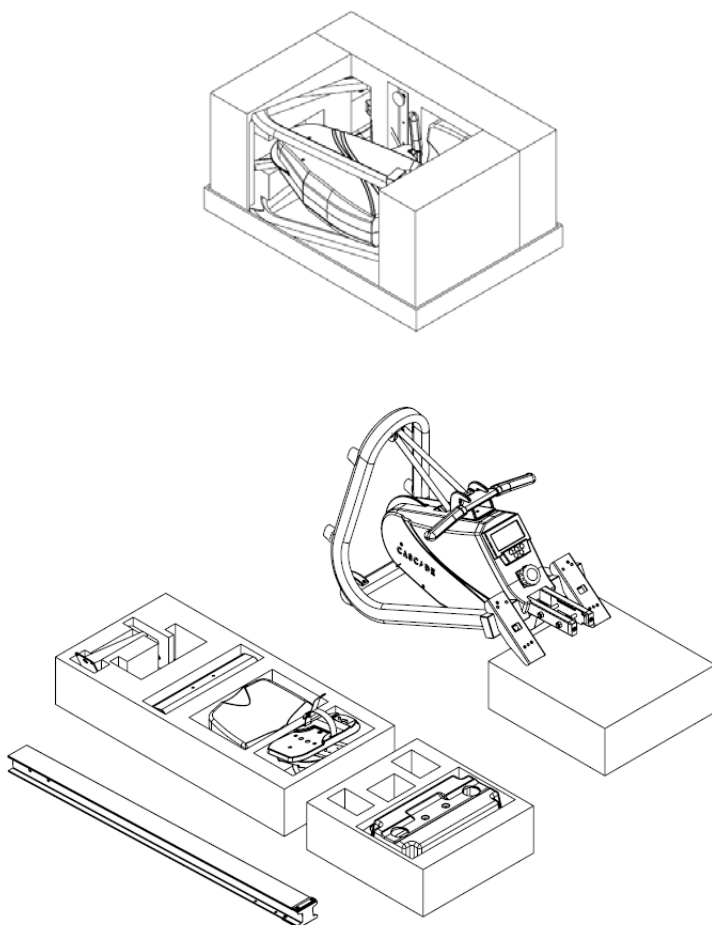

## ASSEMBLY INSTRUCTIONS

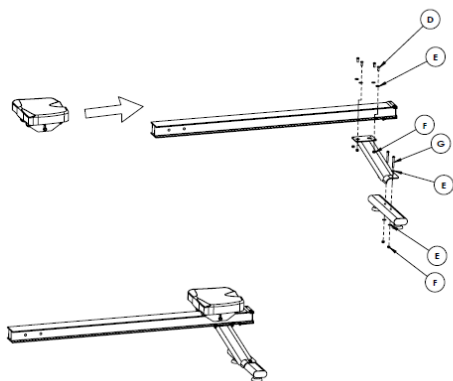

NOTE: Tighten bolt (D) & Nut (F) with allen key (AA) & Wrench (EE) (14.1 ft-lb)  
Tighten bolt (G) & Nut (F) with allen key (AA) & Wrench (EE) (14.1 ft-lb)

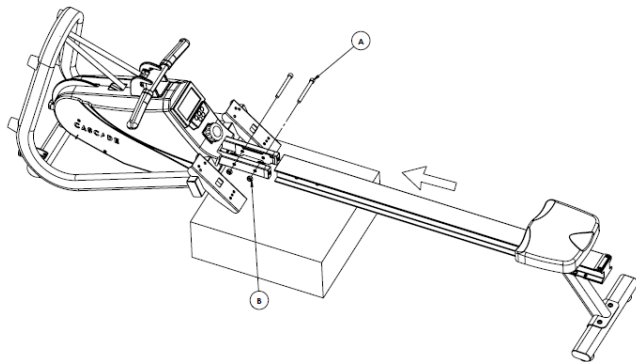

NOTE: Tighten bolt (A) & Nut (B) with allen key (CC) & Wrench (DD) (71.6 ft-lb)

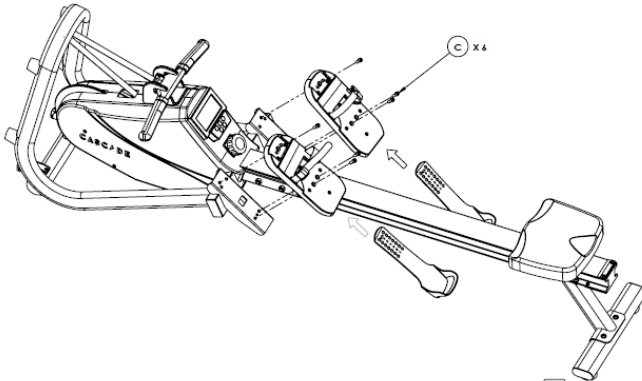

NOTE: Tighten bolt **C** with allen key **BB** (14.1 ft-lb)

- Plug in the power supply to the wall & rower (this will power the console)

### Rower Riser Block

This piece is an accessory item and is not required in order to use the rower. The riser block raises the back end of the rower an additional 5" to create an incline for a more robust workout.

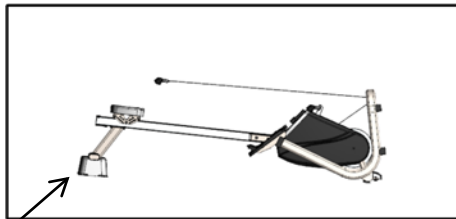

Riser block



### WARNING

THESE GUIDELINES ARE DIRECTED TO YOU, AS THE OWNER OF THIS EXERCISE EQUIPMENT. YOU SHOULD INSIST THAT ALL USERS FOLLOW THE SAME GUIDELINES. YOU SHOULD MAKE THIS MANUAL AVAILABLE TO ALL USERS.

- 1) Obtain a complete physical examination from your medical doctor and enlist a health/fitness professional's aid in developing an exercise program suitable for your current health status.
- 2) When working out for the first time, start out slowly for a minimum of five minutes. After your muscles are warmed up, gradually increase the rowing rate and/or resistance to a speed that allows you to attain your target heart rate zone.
- 3) The speed and duration of your exercise program should always be subject to how you feel. Never permit peer pressure to exceed your personal judgment while exercising.
- 4) Overweight or severely unconditioned individuals should be particularly cautious when using the equipment for the first time. Even though such individuals may not have histories of serious physical problems, they may perceive the exercise to be far less intense than it really is, resulting in the possibility of overexertion or injury.
- 5) Although all equipment manufactured by Cascade Health and Fitness has been thoroughly inspected by the manufacturing facility prior to shipment, proper installation and regular maintenance are required to ensure safety. Maintenance is the sole responsibility of the owner.

### ADJUSTING THE FIT

Take a moment to learn how to properly fit your Cascade Rower Plus to your body; it will make your workouts a more pleasant and safer experience.

The Cascade Rower Plus provides foot adjustability with its foot insert system. Please take a moment to make adjustments to meet your specific needs.

Making full use of these features will give you the most comfortable feel possible and allow you to exercise efficiently. Using the Rower when it is incorrectly adjusted can result in unnecessary discomfort and increase your risk of injury.



### WARNING

DO NOT ATTEMPT TO MAKE ANY ADJUSTMENTS TO THIS EQUIPMENT WHILE EXERCISING ON THE ROWER. STOP YOUR WORKOUT PRIOR TO MAKING ALL ADJUSTMENTS.





### **WARNING**

IF AT ANY TIME DURING YOUR WORKOUT, YOU FEEL CHEST PAIN, EXPERIENCE SEVERE MUSCULAR DISCOMFORT, FEEL FAINT, OR ARE SHORT OF BREATH, STOP EXERCISING IMMEDIATELY. IF THE CONDITION PERSISTS, YOU SHOULD CONSULT YOUR MEDICAL DOCTOR IMMEDIATELY.

- 1) Resistance may be changed at any time by twisting the adjustment knob. For more resistance, turn knob clockwise.
- 2) To dismount the Rower, the seat should be fully stopped. First loosen each toe strap and remove your feet from the foot pads. You are now ready to exit the Rower.

## CONSOLE

**NOTE: Please make sure your power supply is plugged into the wall and the rower prior to starting so that your console will have power**

### DISPLAY

The console is divided into several quadrants containing workout information:

- WATTS: measures how much power is generating during your workout
- PULSE: if you wear a heart rate chest strap your pulse will appear here
- CALORIES: calories burned
- TIME: elapsed time
- TIME/500M: your 500 meter split
- LEVEL: resistance level you are currently on
- METERS: distance travelled in meters
- STROKES: strokes taken during workout
- SPM: strokes per minute rate

### To Activate the Console

There are 2 ways you can activate the console:

- Pick up the handle and take a stroke: you will enter QUICK START program automatically and can just continue with your workout—or— Press the START/STOP button to activate the console. The console will scroll SELECT PROGRAM or QUICK START.

### QUICK START

If you would like to start rowing without using a program—2 ways to do this:

- Pick up the handle and take a stroke: you will enter QUICK START program automatically and can just continue with your workout—or— Press the START/STOP key twice and begin rowing.

### PROGRAMS

If you would like to use one of the (7) programs (TIME, METERS, CALORIES, STROKES, INTERVAL 20/10, INTERVAL 10/20, and INTERVAL CUSTOM):

- Press START/STOP
- Press ENTER: this will display the first program TIME
- Use the UP/DOWN keys to scroll through the programs
- Press ENTER to select the program you want to use

Depending on which program you select you may need to set up parameters for the program. If a section is blinking, you will need to:

- Press the UP/DOWN keys to set the value
- Press the ENTER key to accept the value and move to next section
- Once all sections are set up, the program name will change to START
- Begin your workout

## **PAUSE**

If you need to take a quick break, press the START/STOP key. The console will stay PAUSED for 1 minute and then will turn off & all data will be lost.

## **RESUME YOUR WORKOUT**

As long as you return before the 1 minute reset, you can press the START/STOP key and you can continue your workout.

# GENERAL EXERCISE GUIDELINES

## **SETTING A GOAL**

The first step to a successful exercise program is to set realistic goals and objectives. Do you want an exercise program that is geared to build muscle, maintain muscle tone, increase aerobic capacity, or lose weight? In order to ensure that you fully receive all the benefits of a sound exercise program, you need to first identify the existence (if any) of risk factors that may influence the design of your exercise program. Based upon a comprehensive analysis of your personal exercise needs and interests, you should then develop (or have developed for you by a competent or trained professional) an individualized program of exercise that is enjoyable, easy, and yet challenging. Your greatest health benefit will come from a lifestyle change that encourages a lifetime of physical activity.

One way to guarantee success in reaching your goal is to eat correctly. A well-rounded diet provides the proteins, carbohydrates, fats, vitamins, minerals, and water necessary for good health. If you are unsure of your dietary needs, seek the advice of your physician, an exercise professional, or visit your local bookstore for more information on nutrition.

### Flexibility Training<sup>1</sup>

Achieving and maintaining an adequate range of motion should always be objectives of a comprehensive exercise program. The warm-up phase of your exercise session should include some type of light warm-up activity to increase both your heart rate and your body temperature, which is then followed by flexibility exercises that are

## GENERAL EXERCISE GUIDELINES

A general exercise program for achieving and maintaining flexibility should adhere to the following guidelines:

Frequency	Daily
Intensity	To a position of mild discomfort
Duration	10–30 seconds for each stretch
Repetitions	2–6 for each stretch
Type	Static, with a major emphasis on the low back and hamstrings area because of the high prevalence of low-back pain syndrome in our society

### Exercise Principles<sup>1</sup>

The American College of Sports Medicine has developed a position paper concerning exercise programs for healthy adults and the need for guidelines. The following recommendations concern the quantity and quality of (exercise) training for developing and maintaining cardiovascular fitness in a healthy adult:

Frequency	3–5 days per week
Intensity	50% – 85% of maximum oxygen uptake (VO <sub>2</sub> max)
Duration	20 to 60 minutes of continuous aerobic activity
Mode of Activity	Any activity that uses the large muscle groups, that can be maintained continuously, and is rhythmical and aerobic in nature
Rate of Progression	
Initial Conditions	4–6 weeks: low end intensity (40% – 60% VO <sub>2</sub> max)
Improvement Stage	6 weeks to 6 months: moderate intensity, moderate duration

<sup>1</sup> Some of the material contained in this section was adapted from “The StairMaster® Fitness Handbook, 2nd Ed”, by James A. Peterson and Cedric X. Bryant (editors), Sagamore Publishing, 1995.

## MAINTENANCE

### MAINTENANCE INSTRUCTIONS

#### Helpful Hints

The safety level given by the design of this equipment can only be maintained when the equipment is regularly examined for damage and wear. Inoperable components should be replaced immediately or the equipment should be put out of use until it is repaired. Read all maintenance instructions thoroughly before beginning work.

#### INITIAL SERVICE

Upon receiving your equipment, use a soft clean cloth to wipe off the dust that may have accumulated during shipping. Your equipment will need minor assembly. Refer to the "Assembly Instructions" section of this manual for details.

#### MAINTENANCE SCHEDULE

Part	Recommended Action	Frequency	Cleaner <sup>2</sup>	Lubricant <sup>2</sup>
Foot insert/holder	Ensure that the foot insert screws are tight and the foot straps are not frayed	Before each use	N/A	N/A
 <b>WARNING:</b> WHEN USED IN A CLUB SETTING IT IS CRITICAL THAT THE FOOT INSERT/HOLDER BE CHECKED AFTER EACH CLASS TO ENSURE PROPER INSTALLATION. FAILURE TO DO SO MAY RESULT IN PROPERTY DAMAGE AND/OR PARTICIPANT INJURY.				
Frame	Wipe down	Daily	Soap & water; or, diluted non-abrasive cleaning solution <sup>1</sup>	N/A
Flywheel	Wipe down	Weekly	WD-40® spray. Spray on rag & apply light coat to sides of flywheel.	N/A
Belt	Inspect for correct tension; replace cracked, frayed, or otherwise non-uniform belt	Monthly	N/A	N/A

<sup>1</sup>Use of lubricants or cleaning solutions other than those so specified will result in diminished performance and a shorter life span for that part.

## SPECIFICATIONS

### PHYSICAL DIMENSIONS

- Length: 90"
- Height: 28"
- Width: 20.6"
- Weight: 154 lbs.

### SHIPPING CARTON DIMENSIONS

#### Box 1

- Length: 45 in (114.3 cm)
- Height: 32 in (81.28 cm)
- Width: 23 in (58.42 cm)
- Weight: 115 lbs. (52.16 kgs)

#### Box 2

- Length: 60 in (152.4 cm)
- Height: 7 in (17.78 cm)
- Width: 6 in (15.24 cm)
- Weight: 19 lbs. (8.61 kgs)

# EXERCISE LOG

Week #:	Date	Distance	Calories	Time	Comments
Day					
Monday					
Tuesday					
Wednesday					
Thursday					
Friday					
Saturday					
Sunday					
Weekly Totals					
Weekly Goals:					

# EXERCISE LOG

Week #:	Date	Distance	Calories	Time	Comments
Day					
Monday					
Tuesday					
Wednesday					
Thursday					
Friday					
Saturday					
Sunday					
Weekly Totals					
Weekly Goals:					



# EXERCISE LOG

Week #:	Date	Distance	Calories	Time	Comments
Day					
Monday					
Tuesday					
Wednesday					
Thursday					
Friday					
Saturday					
Sunday					
Weekly Totals					
Weekly Goals:					

CASCADE HEALTH AND FITNESS LLC  
PO BOX 1318  
WOODINVILLE WA 98072  
PHONE: (425) 402-4062  
FAX: (425) 402-4063  
EMAIL: [info@cascadehealthandfitness.com](mailto:info@cascadehealthandfitness.com)  
[www.cascadehealthandfitness.com](http://www.cascadehealthandfitness.com)